

Simulation Of Energy Management System in Grid with Wind System Using Converter Topology

Harshkumar S. Sharma¹, Dr. Vikram V. Patel²

¹Research Scholars (Phd Student), Hansaba College of Engineering and Technology, Gokul Global University, Sidhpur, Gujarat

²Associate Professor, Gokul Global University, Sidhpur, Gujarat

ARTICLE INFO

Received: 18 oct 2024

Revised: 10 Dec 2024

Accepted: 28 Dec 2024

ABSTRACT

In recent years, the power demand has increased which led to power quality issues. The reason for increase in demand is mainly due to rise in population and the new trend of technology. The conventional methods that we used are not capable to meet the increased demand because they are dependent on conventional energy resources which are in a limited amount. In this project work the circuit model for the UPQC has been developed to improve power quality in grid-connected wind system and results have been compared with STATCOM by simulating the model in MATLAB/Simulink software. The output of WECS with and without controller is observed through simulations. The THD analysis has also been carried out for comparative analysis of STATCOM and UPQC devices' performance for power quality enhancement.

Keywords: EMS, Grid, Converter, etc..

I. INTRODUCTION

The recent development in power electronics led to development of solid-state controllers, which are in use with industry, commercial and domestic sectors extensively. The quality of power is being deteriorated due to use of these electronic controllers, which in turn demands quality power from source. A distribution system faces power quality (PQ) problems related to load current and supply voltage. Current related PQ issues are distorted and unbalanced source currents, poor power factor, and source neutral current, whereas voltage related PQ issues are sag, swell, unbalance, flicker, and distortion [1]. Energy is required a wide range of applications such as transportation, industrial applications, agricultural application, household requirements and office application. It can have many forms like heat energy, electrical energy, chemical energy, nuclear energy, light energy and so on. The use of energy plays important role in one's life. The availability and accessibility of sufficient amount of energy accelerate individuals and nation's development. The relation between social developments and use of energy very clear nation with more use of energy are in more advance state of development. Since the use of energy has become an integral part of our life, its supply should be secure and sustainable. At the same time, it should be economical, environmentally friendly and socially acceptable. The current trend in energy consumption is neither secure nor sustainable. The raising consumption of fossil fuel, together increasing greenhouse gas emission, threatens our secure energy supply.

There are two types of energy sources,

- Renewable Energy (Non-conventional)
- Non Renewable Energy (conventional)

As the non-renewable energy sources like oil, coal, natural gas, nuclear etc. are reducing fast and the cost of the energy is rising, the renewable energy sources like wind, solar, biomass, water, geothermal etc. become an alternate for energy. Conventional energy sources based on oil, coal and natural gas have proven to be highly effective drivers of economic progress but at the same time damaging to the environment and to human health. Furthermore, they tend to be cyclical in nature due to the effects of oligopoly in production and distribution. With the ever increasing proliferation of renewable energy resources and nonlinear power electronic loads, there is an increasing demand for

power electronic systems which combine distributed generation capability along with active filtering. The nonlinear loads which include computer power supplies and small adjustable speed drives inject harmonic currents into distribution networks which leads to distortion of voltage at point of common coupling (PCC). The commonly used power conditioning systems for power quality improvement are static compensator (STATCOM), dynamic voltage restorer (DVR) and unified power quality conditioner (UPQC). STATCOM is a shunt compensator which compensates for the load current problems such as reactive current, harmonics etc. DVR is a series compensator which protects sensitive loads against grid voltage disturbances such as sags/swells. UPQC consists of both shunt and series compensators which are connected back to back through a common DC-link. It combines functionality of both STATCOM and DVR.

Distributed generation integrated with UPQC has been described in research papers. PV-UPQC is robust to grid voltage variations and thus has enhanced fault ride through capabilities as compared to a conventional grid connected PV inverter. A major part in the control of PV UPQC involves the extraction of fundamental active load current and fundamental component of grid voltage. The signal extraction techniques for active filters can be broadly classified into time domain techniques and frequency domain techniques. The commonly used methods for extraction of fundamental load current are instantaneous reactive power theory (p-q theory), synchronous reference frame theory and instantaneous symmetrical component theory. Adaptive filtering based techniques such as adaptive notch filter are another important method for extraction of fundamental active current. Adaptive filtering for extraction of fundamental active component of load current has been reported in [1].

II. BACKGROUND & OBJECTIVES

Background

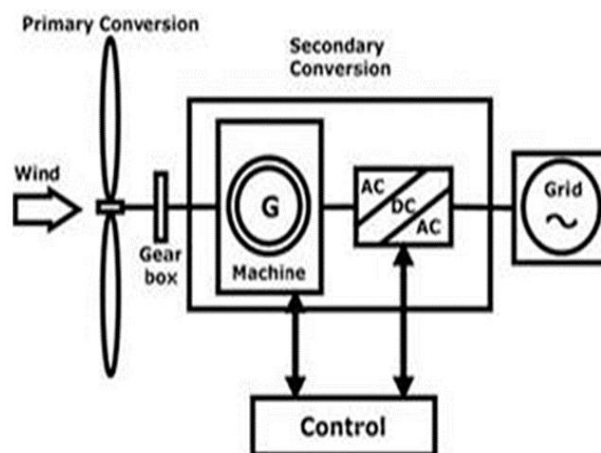

Fig.1. Grid Connected Wind System [1]

Induction generator (IG) is a type of AC generator to produce power to the system. When induction motor runs more than synchronous speed (N_s) i.e. negative slip acts as an IG [1]. In rotor operation stator flux induces the rotor current which creates the rotor with polarity opposite to stator. The slip of rotor and stator becomes equal. The configuration of grid connected wind system is shown in Fig. 1. In generating mode, the prime mover and engine drives the rotor above the N_s . The opposing rotor flux is cutting the stator coils as stator still induces currents in the rotor that's how active current is generated in stator and motor operate as generator. In standalone IG, the magnetizing flux is provided by the capacitor bank connected in parallel with induction generator and it draw magnetizing current from the grid in grid connected induction generator.

The value of frequency and voltage of the machine in standalone system is very small compared to the grid connected system. Two schemes are developed for the operation of WECS with IG:-

- Fixed speed drive scheme -the shaft speed is kept constant for whole range of wind speed by pitch control mechanism. This type of schemes is limited for low rating machines. SCIG is the example of fixed speed drive scheme.
- Variable speed drive scheme- variable speed is maintained by use of power electronics devices. Variable V & variable F output from generator is first rectified and then converted to fixed V and F by use of an inverter [1]. WRIG, DFIG are examples of variable speed drive.

The Fixed Speed Induction Generator (FSIG) is an established technology in the field of wind generation. 23% of the wind generators operating worldwide are of FSIG type [1]. However, the provision of reactive power compensation and ensuring the fault ride through capability for this type of generator is a challenging task. Whenever a fault occurs in the power system, a voltage sag of varying depth is experienced at the machine terminals. This is accompanied by a significant reactive power requirement from the connecting power system. As FSIG is a reactive power sink, it needs an external device to fulfil its reactive power requirement even during normal operating conditions. The mismatch in the electrical and mechanical torque during the sag period causes over-speeding of the machine. The limit of stability of the machine is reached once the slip approaches its critical value. In this situation, the generator fails to build its terminal voltage and it will be tripped by the under-voltage or over-speed relays [2-3]. This tripping can cause serious problems for the system security and can lead to large generation deficit as wind energy penetration level increases. Therefore many countries worldwide have considered revising their grid codes which were originally developed for conventional generators. The ability of Wind Generation to remain connected to the grid in the event of system faults and dynamic reactive power compensation are aspects of these grid codes, which have received particular attention.

Objectives

The power system liberation, along with generation shortage and transmission restriction, has modified the grid conditions by providing space for energy storage devices and its new developed technology performing very important role in bettering power quality and system reliability. The benefits of such storing devices are that it can damp oscillations rapidly, reduces sudden load transients and maintain continuity of supply while a load interruption occurs in transmission or distribution system. The small size energy storing device used in wind generation system can give rated power for very short duration of time and would capable to reduce short term voltage disturbance and so improving power quality. But if there is larger energy reserve connected with wind farm then it can give power certain amount of power for longer duration of time. This increases the availability of power form wind farm and allows shutdowns for smaller stand by units at peak load time. By some means if the size of energy reserve can increase then it allows to make standby some of larger power plants which justify the investment on the whole system. The integration of wind farms with power grid leads to Power Quality (PQ) issues such as voltage sag, swell, flicker, harmonics etc. Most of the industrial and commercial loads are of non-linear type which indeed the starting place of harmonics. As 70% of PQ problems are voltage sag which is one of the most severe disturbances to sensitive loads. As an outcome of the aforementioned issues both consumer sector and production sector gets affected with poor quality of power which urge PQ enhancement at its best level. Among many of custom power devices, Static Compensator (STATCOM) and Unified Power Quality Conditioner (UPQC) is the only device used to diminish both voltage sag and current harmonics. This project analyzes PQ problems, voltage sag and current harmonics due to the interconnection of grid connected wind turbine and also provides PQ enhancement by introducing UPQC.

The Main objectives of this project are:-

- ***Simulation of Wind farm with STATCOM***
- ***Simulation of Wind farm with UPQC***
- ***Comparison for Voltage Regulation in Wind farm system for STATCOM and UPQC both Devices***

- **THD Analysis**

III. STATCOM & UPQC FOR POWER QUALITY

STATCOM IN POWER QUALITY IMPROVEMENT

STATCOM (Static Compensator) consists of one SVC with capacitor on dc side and other with transformer [1]. A basic STATCOM with Voltage Source Converter (VSC) is connected in shunt to the system through a coupling transformer. The three phase voltages are in-phase and synchronized with an AC system which is considered as grid through the reactance of a coupling transformer. The adjustment of phase and magnitude of these voltages at the output of the STATCOM allows to effectively controlling the exchange of active and reactive power between the STATCOM and the grid. STATCOM acts as interlink between renewable resources and grid system and also for real power exchange between them. STATCOM is an electronic device having no inertia so it is better than synchronous condenser. When load requires Q power STATCOM takes active part in delivering the Q power to the load. When Q current component of the STATCOM is lags by 90°, it's in absorbing mode when it is leads by 90°, and it's in delivering mode. STATCOM operates in dual mode which gives both inductive and capacitive compensation. The inductive compensation is more important as it provides compensation when over compensation occurs due to capacitor banks. Reactive current control scheme is used in STATCOM. The three phase line voltage is used to compute the reference angle. Quadrature component is compared with reference which is desired. The error obtained is amplified through error amplifier which produces angle α. Quadrature component of converter is either positive or negative. Positive when STATCOM acts as inductive reactance and negative when STATCOM acts as capacitive reactance. The control system shows inner the reactive current flow through STATCOM leaving line voltage. Q power is compensated by injecting current. The current injected is from the capacitor bank which is produced by absorbing P power by AC system.

$$I_q = \frac{U_t - U_{eq}}{X_{eq}} \dots\dots\dots (5.1)$$

Where U_{eq} is the equivalent Thevenin voltage, I_q is the reactive current injected by the STATCOM, X_{eq} is the equivalent Thevenin reactance.

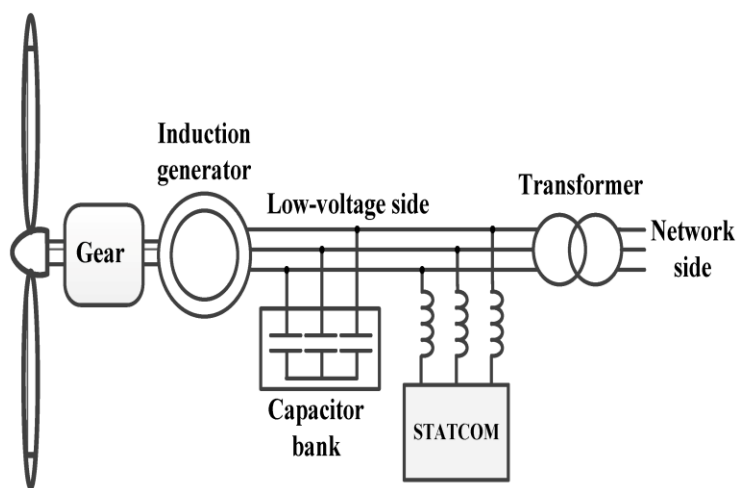

Figure 2 STATCOM with Wind Power System

UPQC IN POWER QUALITY IMPROVEMENT

In recent years, UPQC is employed to produce sensible quality of power to the shoppers. UPQC could be a combination of series and shunt compensator through a typical dc link electrical capacitor to limit the harmonics content within limit obligatory by IEEE-519 normal. The series a part of UPQC is referred as Dynamic Voltage refinisher (DVR), which is employed to take care of balanced, distortion less nominal voltage at the load end. DSTATCOM is shunt part of UPQC which is employed to compensate load Q power, harmonics and balance the load

I by maintain the supply current balanced and harmonic free with unity power. General diagram of UPQC with Wind Power is shown in Fig. 3.

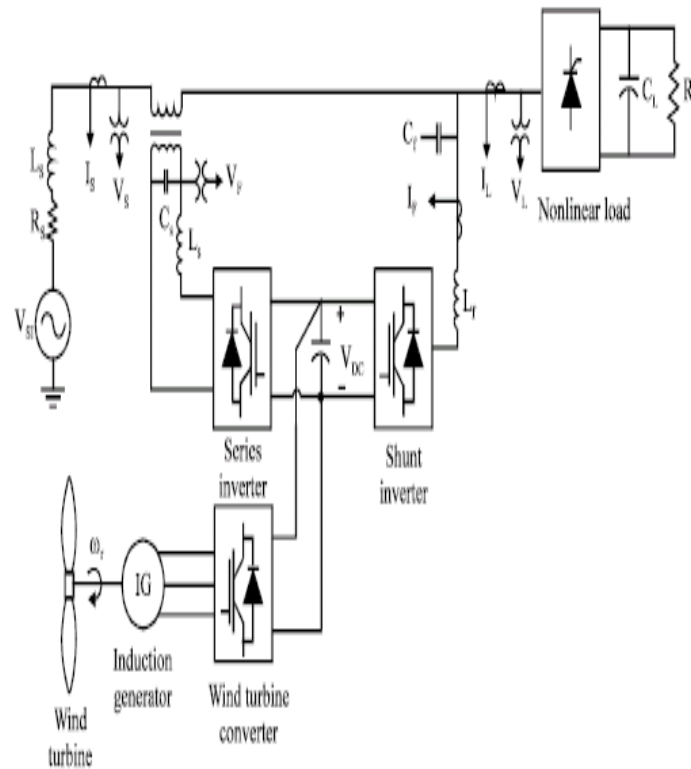

Figure 3 UPQC with Wind Power System

They inject series voltage and shunt currents to the system. These devices atone for power quality (PQ) disturbance like current harmonics and voltage sag and swell to guard sensitive load moreover on improve service dependableness. There are several strategies to alleviate voltage sags and swells; however, the employment of custom power (CP) device is taken into account to be the foremost economical methodology to serve for different purposes. CP devices are planned for enhancing the standard and reliability of the electrical power. Custom Power suggests that no power interruptions, low harmonic distortion in load voltage, acceptance of fluctuations underneath voltage among such as limits, low section unbalance, low flicker at the section voltage, magnitude and period of over voltage and poor power issue hundreds while not vital error on the terminal voltage.

In series control scheme the active series filter is providing for the voltage recompense. It generates the recompense voltage i.e. made by the PWM converter and insert in sequence with the provide voltage to force the voltage of Point of Common Coupling (PCC) to suit fair and sinusoidal. In shunt control scheme the active shunt power filter provides current and Q power (if the system requires) compensation. It would act as a controlled current generator that compensates the load current to power the source currents exhausted from the system to be unbiased which is in phase and sinusoidal with the positive sequence system voltage.

IV. SIMULATION AND RESULT DISCUSSION

Simulation of Wind System with STATCOM

STATCOM connected in parallel with the system and injects current in it to compensate for reactive power. Hysteresis control technique is used which gives correct switching for STATCOM. The control system shows inner the reactive current flow through STATCOM leaving line voltage. Q power is compensated by injecting current. The current injected by STATCOM which is produced by absorbing P power by AC system. STACOM is designed with the help of IGBT/diode power electronics devices.

Fig.4 shows complete model of grid connected wind system using STATCOM. Here STATCOM is connected with the grid connected wind energy system. The STATCOM controlled scheme is used for improving the power factor, voltage and current. Here the input value is set for wind i.e. 10 as there will be any change in the wind speed the feedback is given to the STATCOM which will compensate the desired voltage or current required by the system which improves the power factor the system.

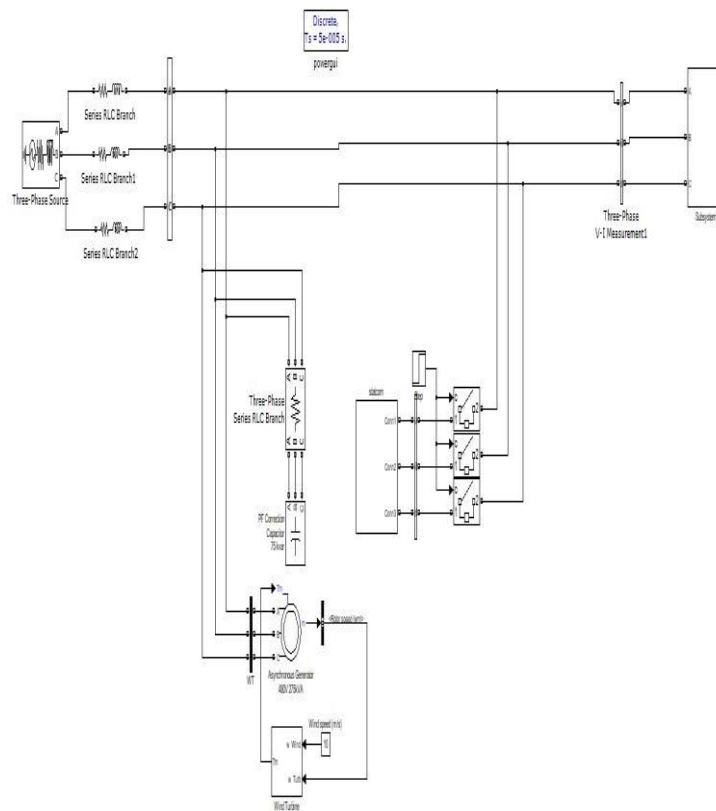

Fig 4- Complete model of grid connected wind system using STATCOM

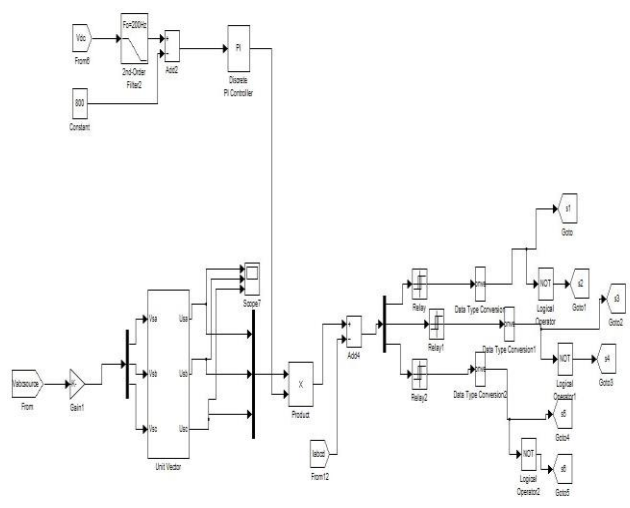

Fig 5- VSC control subsystem for STATCOM

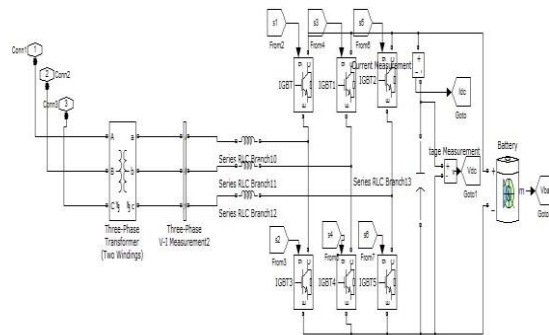

Fig 6-VSC converter subsystem of STATCOM

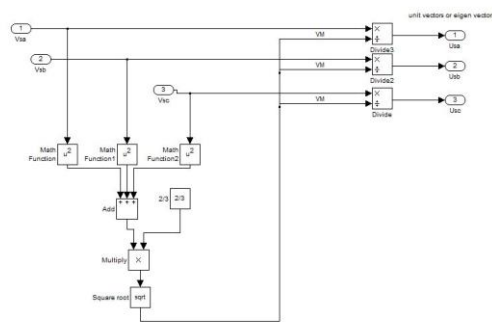

Fig 7- Unit Vector Controlling subsystem

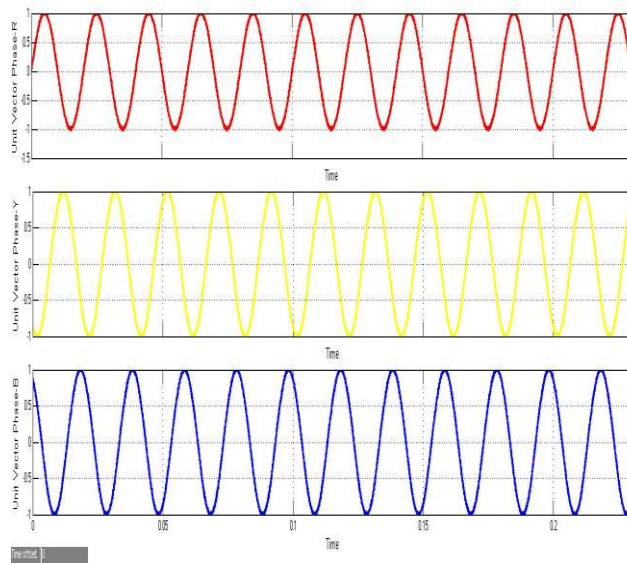

Fig 8- Three phase controlled unit vector output

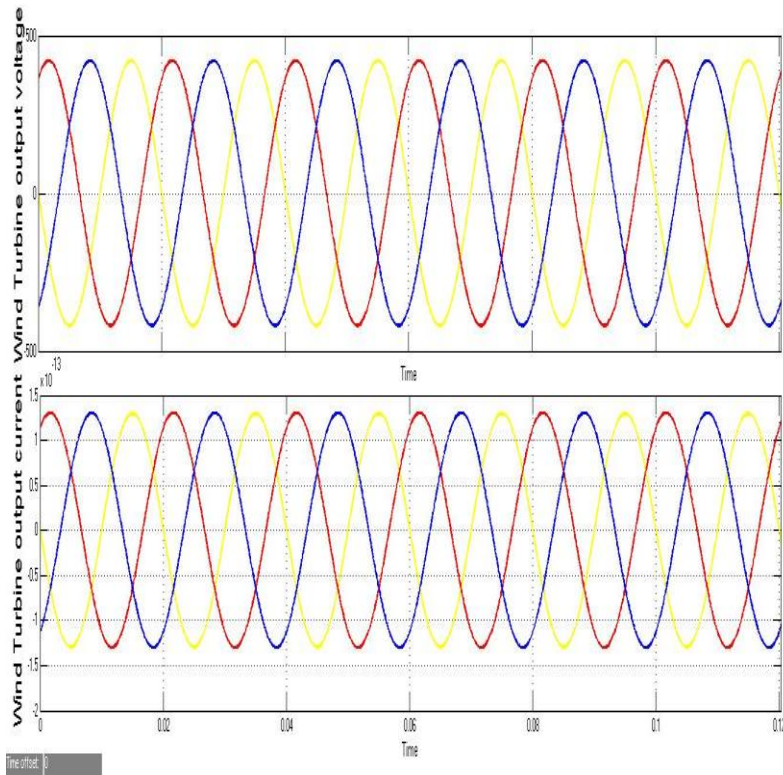

Fig 9- Wind output voltage and Current

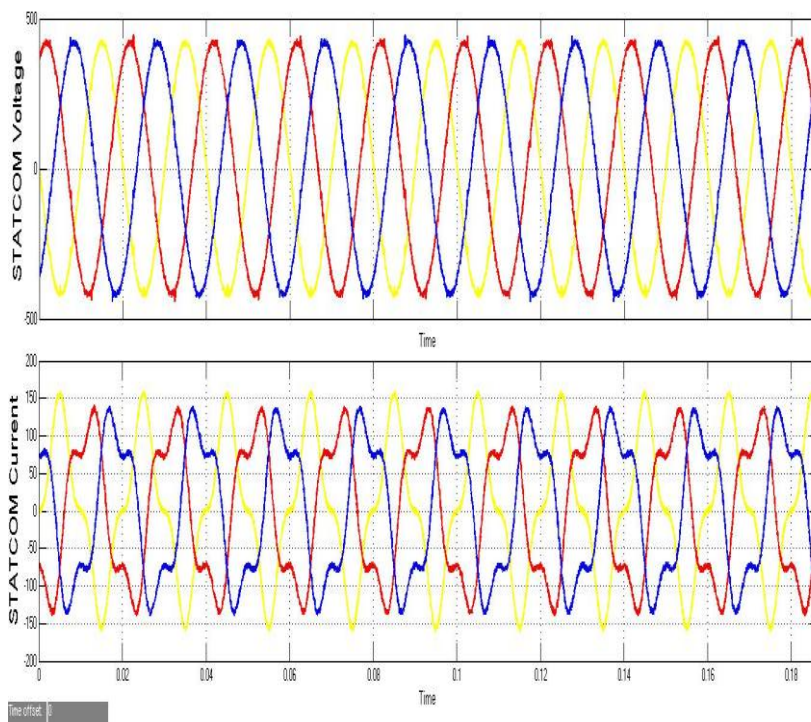

Fig 10- STATCOM controlled voltage and current

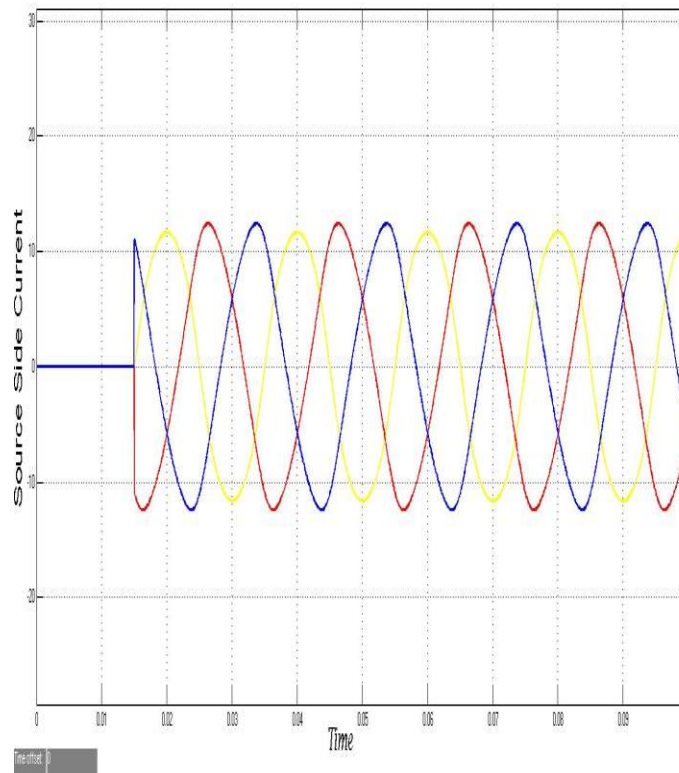

Fig 11- Source Side injecting current

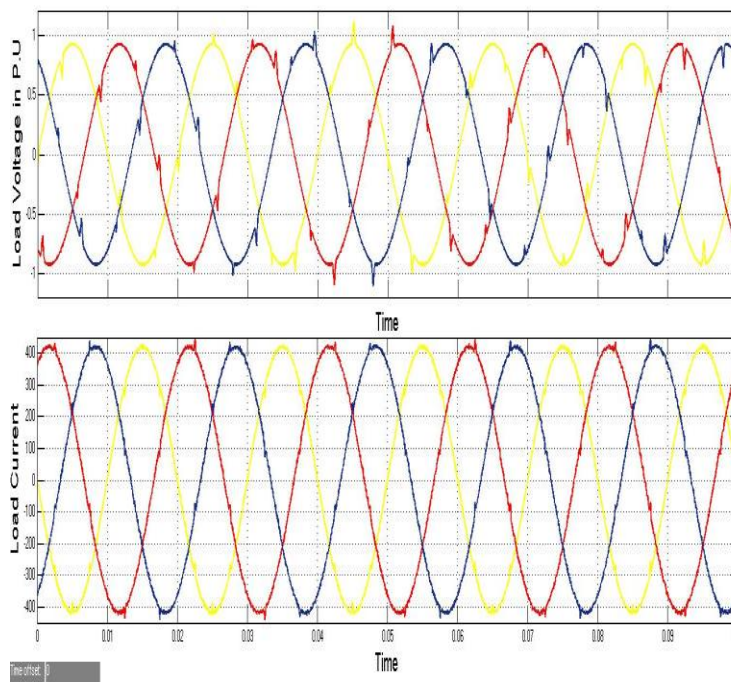

Fig 12- Load side output voltage and current using STATCOM

THD Analysis

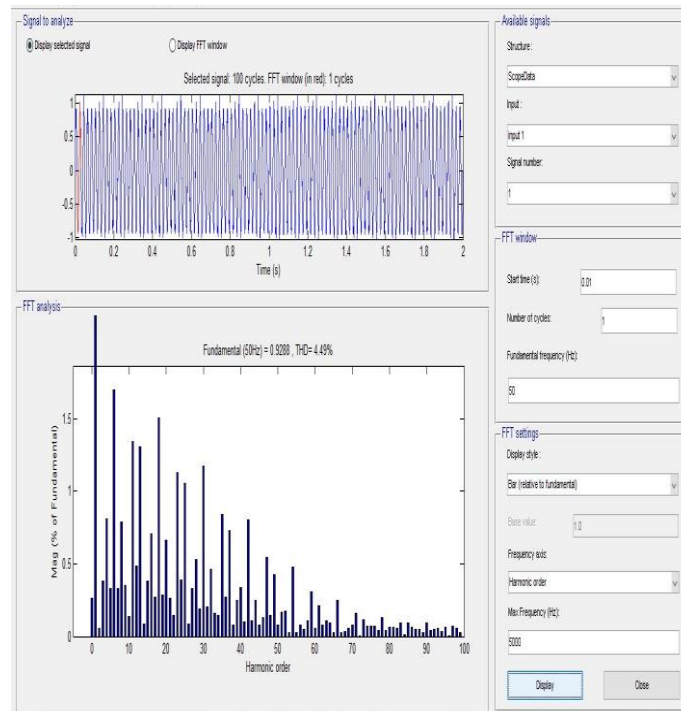

Fig 13- THD value of grid voltage connected WECS with STATCOM

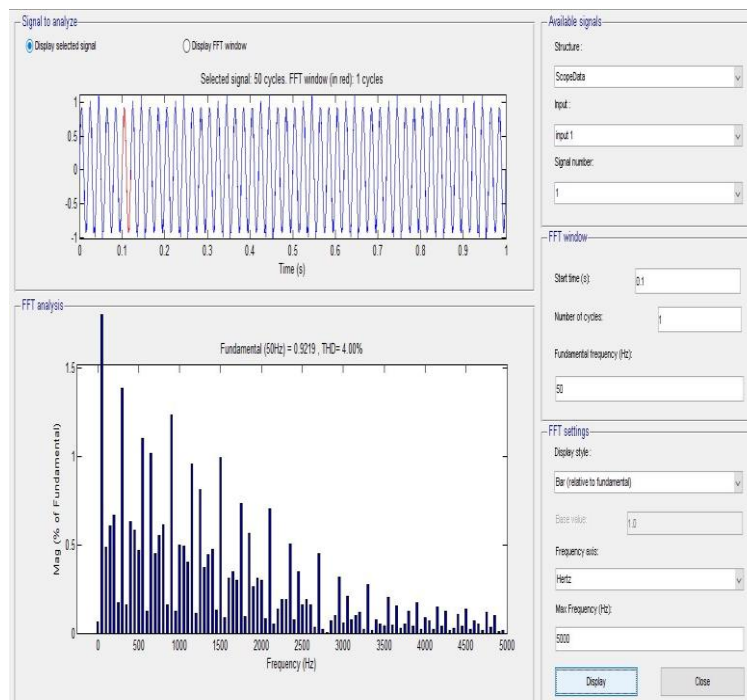

Fig 14- THD value of grid Current connected WECS with STATCOM

V. CONCLUSION

In this work, the renewable energy that is wind energy is used for power production. By using UPQC the PQ of grid connected wind system is improved having nonlinear load. The power quality issues are described briefly which is to be improved. Compensation of reactive power is most important for the power quality improvement. STATCOM and UPQC are used in proposed work for PQ improvement in grid connected WECS. STATCOM maintain the source

voltage and current in phase. STATCOM provides control of reactive power only whereas UPQC provides control of both real and reactive power. Here the input value is set for wind i.e. 10 m/s as there will be any change in the wind speed the feedback is given to the controller which will compensate the desired voltage or current required by the system which improves the power factor the system without any losses. Therefore, the overall efficiency of the system will increase. Based on analysis of simulation results, it is verified that system shows an excellent performance using UPQC as compared to STATCOM.

REFERENCES

- [1] Amita, Abhishek Kumar Sinha, "Power Quality Comparison of grid connected wind energy system with STATCOM and UPQC", 2018 International Conference on Intelligent Circuits and Systems, 978-1-5386-6483-4/18/©2018 IEEE, DOI 10.1109/ICICS.2018.00079.
- [2] Li Shengqing, Xu Wenxiang, Li Weizhou, Zeng Huanyue "Wind farm grid voltage stability researching based on Cascade STATCOM", 978-1-5257-1458-2/16/©2016 IEEE
- [3] Jayanti N. G., Malabika Basu, Michael F. Conlon, Kevin Gaughan "STATCOM AND UPQC: OPTIONS TO ENHANCE FAULT-RIDE-THROUGH CAPABILITY OF A FIXED SPEED WIND GENERATOR", 978-1-5090-1458-7/17/©2017 IEEE.
- [4] Qiuwei Wu, Jose Ignacio Busca Solanas, Haoran Zhao, àukasz Hubert Kocewiak, "and Wind Power Plant Voltage Control Optimization with Embedded Application of Wind Turbines and STATCOM", 978-1-5090-6173-0/16/©2016 IEEE.
- [5] Sukriti Solanki, S.C. Mittal, "Study of 6MW Wind Farm with and without STATCOM using MATLAB/SIMULINK", 2013 Third International Conference on Intelligent System Design and Engineering Applications
- [6] R. M. M. Pereira, C. M. M. Ferreira, Member, IEEE and F. P. M. Barbosa, "Comparative Study of STATCOM and SVC Performance on Dynamic Voltage Collapse of an Electric Power System with Wind Generation", 978-0-7695-4923-1/12© 2012 IEEE.
- [7] M.F. Farias, P.E. Battaiotto, M.G. Cendoya, "Investigation of UPQC for Sag Compensation in Wind Farms to Weak Grid Connections", 978-1-4799-5115-4/14/2014 IEEE'.
- [8] Fang LI, Jilin Electric Power Survey & Design Institute, "A Study on STATCOM for Voltage Stability of Wind Power System", ICICIC-2017, IEEE.
- [9] Andrea Staino, Biswajit Basu, Malabika Basu, "Suppression of Grid Fault-induced Vibration in Wind Turbines using UPQC", 978-1-61284-722-1/15/©2015 IEEE.
- [10] E. Muljadi, C.P. Butterfield, "Wind Farm Power System Model Development", 2011 International Conference on Mechatronic Science, Electric Engineering and Computer August 19-22, 2011, Jilin, China, 978-1-61284-722-1/11/©2011 IEEE
- [11] T. Ackermann, Ed., Wind Power in Power Systems, 2005, Chichester, England: John Wiley Sons, Ltd.
- [12] E. Muljadi, C.P. Butterfield (2004), "Wind Farm Power System Model Development", World Renewable Energy Congress VIII, Colorado, Aug-Sept 2004.
- [13] L. Chun, J. Qirong, X. Jianxin (2000), "Investigation of Voltage Regulation Stability of Static Synchronous Compensator in Power System" IEEE Power Engineering Society Winter Meeting, vol. 4, 2642-47, 23-27.
- [14] Ahmed F Zooba and Ramesh Bansal, "Handbook of Renewable energy sources", (2011) World Scientific Publishing Co. Pvt. Ltd., ISBN-13 978-981-4289-06-1.